

Newfoton

辽宁新福源精密制造科技有限公司

工厂地址：辽宁省鞍山市台安县台安镇台大路  
南工业园区

中文网站：www.asnfb.com

英文网站：www.newfoton.com

矿山备件事业部：0412-7224716

特种轴承事业部：0412-2507077

邮箱地址：2229026093@qq.com

Liaoning Newfoton Precision Manufacturing  
Technology Co.,Ltd.

Taian , Anshan City,  
Liaoning Province, China

Http://www.newfoton.com

Tel: 86 412 7124368

Email: 2229026093@qq.com



辽宁新福源精密制造科技有限公司

Liaoning Newfoton Precision Manufacturing Technology Co.,Ltd.

Newfoton  
重型齿轮生产基地



# CONTENT

## 目录

公司简介 Company Profile	1-2
发展历程 Development History	3-4
企业文化 Company Culture	5
产品目录 Product List	6
设备展示 Machine Capacity	7-10
产品照片 Product Photos	11-24
产品应用 Application	25-32

# 公司简介

## Company Profile

辽宁新福源精密制造科技有限公司位于辽宁省台安县，占地面积15万平方米，主要从事矿业和工业产品备件，回转支承等的设计和生，工艺水平高。经多年发展壮大，现主要产品分为11大类，应用领域涵盖矿业、冶金、工程机械、化工、船用备件、风电、核电、军工航天、清洁能源等。

辽宁新福源精密制造科技有限公司秉承“诚信为本”的质量方针将产品质量作为企业生存的根基。公司通过ISO9001质量管理体系认证，从产品的原材料开始，对铸、锻、热处理、加工、装配、检测等每个环节安排专人进行严格把关。现有大型14米，6.3米数控立车，大型8M数控滚齿机，10M数控铣齿机，及相关镗、铣、刨、钻等配套设备，针对大型备件加工能力强。我们的质量方针就是“产品是打开市场的钥匙，走向世界的桥梁，市场竞争的根基”。

从事机械加工制造多年来，新福源积累了丰富的经验，不断对科研有投入，优化生产手段，配备相关生产检测设备，使产品制造工艺及装备具有良好水平。同时，在发展过程中，注重诚信经营，有着稳定的供应商和合作伙伴，这使我们的产品在国内市场的拓展上奠定了坚实的基础。新福源坚持以质量为立足根本，努力为用户提供品质、服务都满意的产品。

Liaoning Newfoton Precision Manufacturing Technology Co., Ltd. is located in Tai'an County, Liaoning Province, covering an area of 150,000 square meters. It is mainly engaged in the design and production of mining and industrial product spare parts, slewing bearings, etc., with a high level of technology. After years of development and growth, the main products are now divided into 11 categories, with application areas covering mining, metallurgy, engineering machinery, chemicals, marine spare parts, wind power, nuclear power, military aerospace, clean energy, etc.

Liaoning Newfoton Precision Manufacturing Technology Co., Ltd. adheres to the "integrity-based" quality policy and regards product quality as the foundation of enterprise survival. The company has passed the ISO9001 quality management system certification. Starting from the raw materials of the products, the company conducts casting, forging, heat treatment, processing, assembly, and testing. Wait for each link to arrange a special person to strictly check. The existing large 14m, 6.3m CNC vertical lathe, large 8m CNC gear hobbing machine, 10m CNC gear milling machine, and related boring, milling, planing, drilling and other supporting equipment, have strong processing capabilities for large spare parts. Our quality policy is "products are the key to open the market, the bridge to the world, and the foundation of market competition."

Engaged in mechanical processing and manufacturing for many years, Newfoton has accumulated rich experience, has continuously invested in scientific research, optimized production methods, equipped with relevant production testing equipment, and made the product manufacturing technology and equipment have a good level. At the same time, in the development process, we pay attention to integrity management and have stable suppliers and partners, which has laid a solid foundation for our products to expand in domestic and foreign markets. Newfoton insists on quality as the foundation, and strives to provide users with quality and service satisfied product.

## 企业资质

## Company Qualification

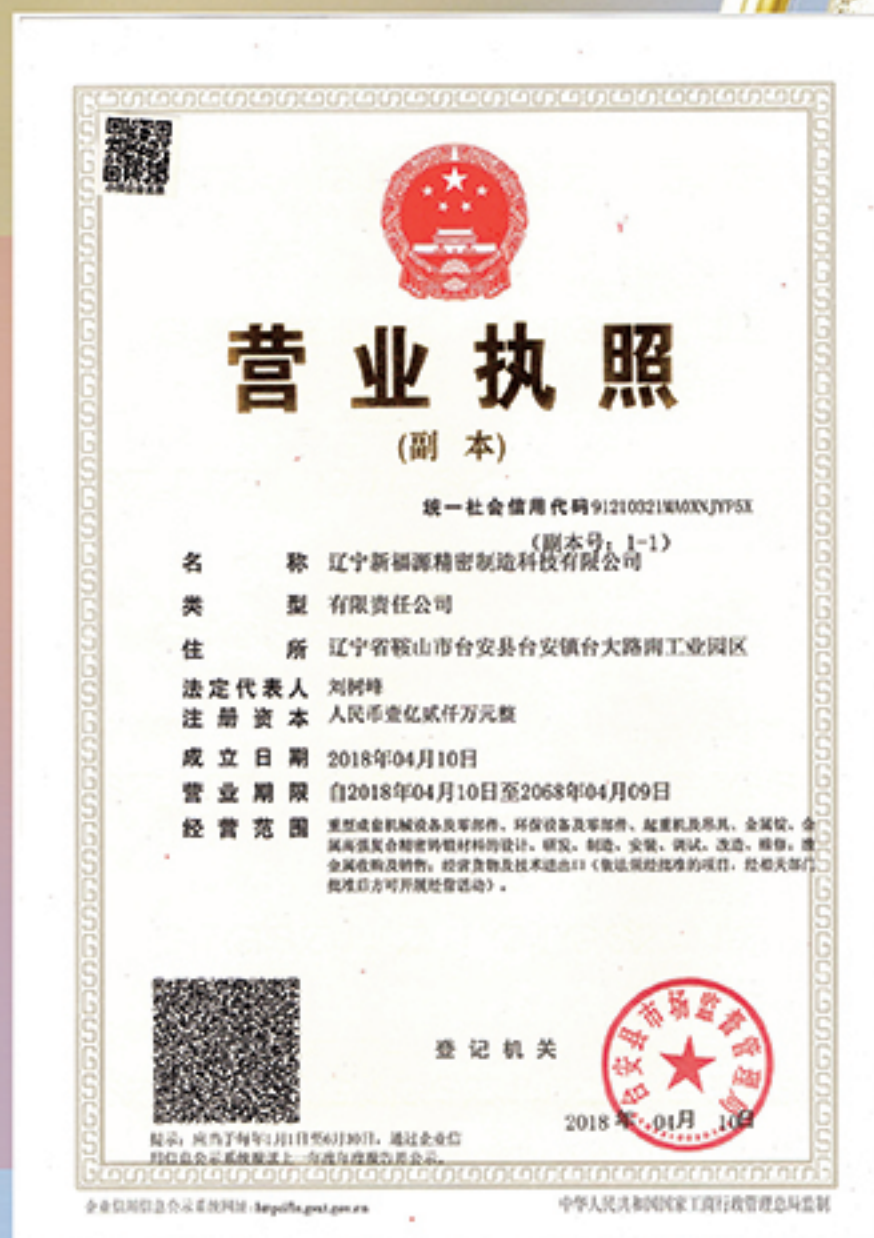

■ 发展历程

Development History

传承、发展

2018

扬帆更远的目标，成立  
辽宁新福源精密制造科技  
有限公司  
Face more ambitious goal!



质量是企业的生命线



在企业不断的发展中，新福源都竭心尽力，一直坚持“质量是企业的生命线”的企业理念，以自身的发展缔造高品质的产品。

**Quality is the lifeline**

Newfoton insist on "quality is the lifeline" to product high quality products.

低质量产品我们不做



高质量产品是企业取得消费者信赖，带来企业竞争优势，减少竞争压力，超越竞争对手的重要保证。

**No low quality products**

High quality products always win the customer trust, and bring competition advantage. High quality products always reduce competition stress and surmount competitors.

重执行、戒空话



任何卓越的企业都必须有强大的执行力。只有有了强大的执行力，他们才能够落实，才能够发挥作用。

**Emphasize execution, stop empty words**

Every excellent enterprise should have powerful execution; the policy can be carried out by powerful execution.

循序渐进，勇于创新



新福源是一个激情豪迈，富有创新勇气的公司。循序渐进，勇于创新，在前期科研基础上，总结经验，继而打破常规，突破束缚，创造新产品，提供新的生长力量。

**Innovation step by step**

Newfoton is passionate and creative, on the basis of scientific achievements, Newfoton summarize experience, break the routine and create the new products to gain growth power.

企业文化

Company Culture

产品目录 Product List

1	齿加工和立车 a. 大,中,小型齿圈齿轮齿条(最大直径14m,模数50) b. 大,中,小型齿轴(最大模数50)	<b>Girth Gear, Gear rack</b> Max. Diameter: 14m Max module: 50 Gear Shaft Max. Module: 50
2	矿山备件 绳轮, 轮带, 托辊, 破碎锥等	<b>Mining parts:</b> rope pulley, tyre, roller, crusher cone and so on.
3	轴承类 a. 回转支承 b. 回转驱动 c. 轧机轴承	<b>Bearing:</b> a. Slewing ring b. Slew drive c. Rolling mill bearing
4	整机类 a. 破碎机 b. 振动筛 c. 球磨机	<b>Mining equipment:</b> a. crusher b. Vibrating screen c. Ball mill
5	起重设备 各种规格单,双梁起重机,吊车,起重能力100吨	<b>Hoisting equipment:</b> Single-beam crane Double-beam crane
6	高精度齿轮箱、重型减速机, 消除齿轮箱	<b>High precision gearbox, Heavy Reducer, Backlash gearbox</b>
7	各种类型铆焊机加工非标设备, 结构件	<b>Welding structural parts</b>
8	铜件, 巴氏合金件, 锰钢耐磨件	<b>Copper, Babbitt, Mn wearing parts</b>
9	容器类 a. 镁合金坩埚 b. 焊接渣罐 c. 化工储罐	<b>Container:</b> a. Magnesium alloy crucible b. Welding slag pot c. Chemical storage tanks
10	机床类 a. 各种规格动,定梁立车 b. 齿轮加工机床	<b>Machinery:</b> a. Moving beam lathe, Fixed beam lathe b. Gear Hobbing machine, Gear milling machine
11	热处理 a. 中频淬火 b. 高频淬火 c. 氮化 d. 调质	<b>Heat-treatment:</b> a. Medium-frequency quenching b. High-frequency quenching c. nitriding d. tempering and quenching.

■ 设备展示

Machine Capacity

一、滚齿机 铣齿机  
CNC Gear Hobbing Machine and  
Gear Milling Machine



小型滚齿机群  
Small Gear Hobbing Machines Group



齿轮轴滚齿机  
Gear Shaft Hobbing Machine



14米铣齿机 模数40  
14m Gear Milling Machine  
Max. Module: 40

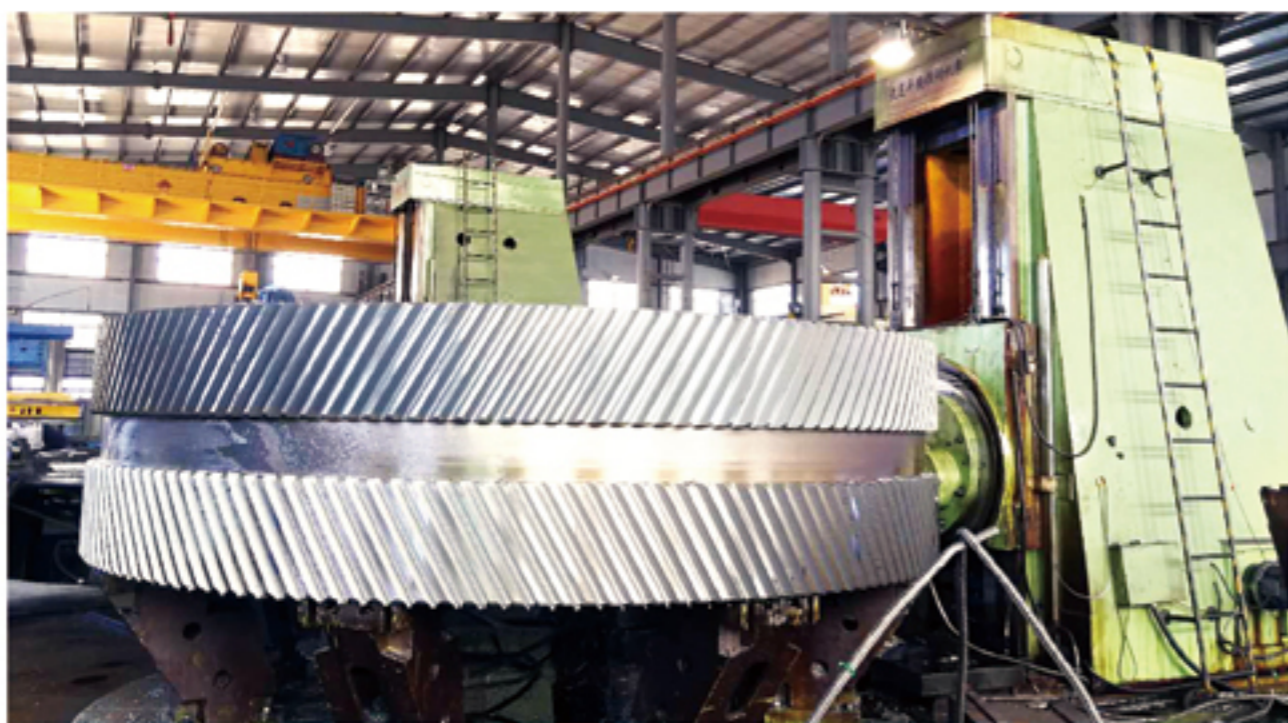

8米、14米滚齿机 直径：8m、14米 模数：40、50  
8m, 14m Gear Hobbing Machine Diameter: 8m, 14m Module: 40, 50



6.3米滚齿机  
6.3m Gear Hobbing Machine



5米人字铣  
5m Double Helical Gear Milling Machine

二、数控立车  
CNC Vertical Lathe



14m数控立车  
14m CNC Vertical Lathe



4m 数控立车  
4m CNC Vertical Lathe



5m双柱立车  
5m CNC Vertical Lathe

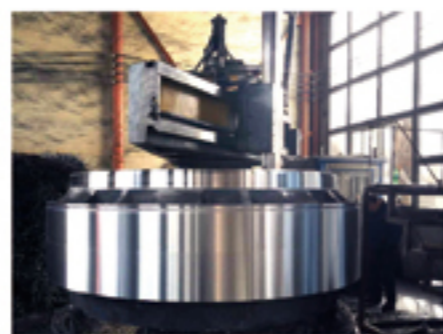

6.3m数控立车  
6.3m CNC Vertical Lathe

三、卧车及其他设备  
Horizontal Lathe and Other Equipment



1.8m数控卧车  
1.8m Horizontal Lathe



1.25m数控卧车  
1.25m Horizontal Lathe



起重设备 载重量100t, 32t, 20t, 10t  
Hoisting Equipment Load Capacity 100t, 32t, 20t, 10t



热处理炉  
Thermal Treatment Furnace

工业备件

Industrial Parts



支承辊/ Supporting Roller



二分齿/ Girth Gear M=32 Φ=8.2m



减速机箱体/ Gear Reducer Box H=1.8m L=3m



四分齿/ Girth Gear M=45 Φ=8.4m

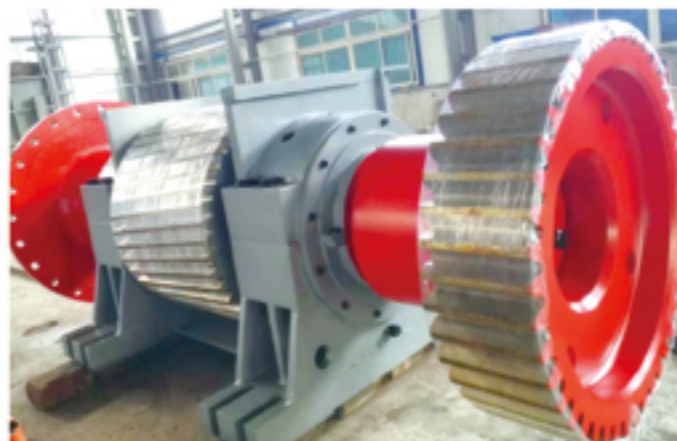

球磨机驱动齿轮/ Drive Gear of Ball Mill



四分伞齿/ Bevel Gear M=36 Φ=8m



托辊/ Supporting Roller



轴承座/ Bearing House



回转窑出料口/ Outlet of Rotary Kiln



齿轴/ Gear Shaft L=3.4m



工业备件

Industrial Parts



齿圈轮带/ Girth Gear Tyre  $\Phi=5.4m$



铆焊链板/ Weld Chain 宽度/ Width= 1.7m



托轮/ Riding Wheel  $\Phi=1.5m$

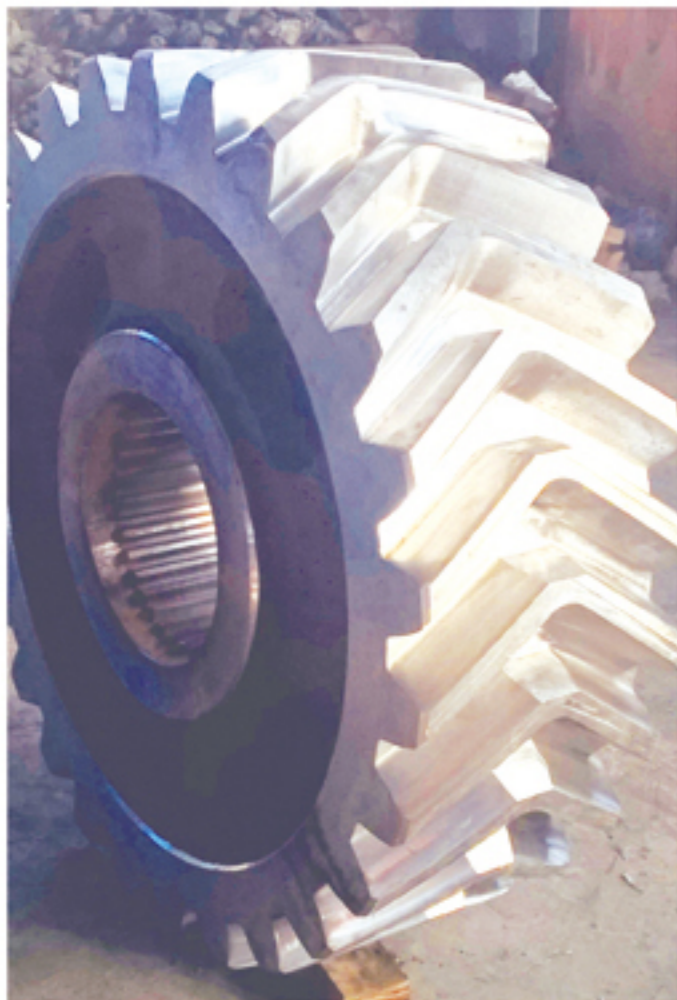

电铲人字齿/ Double Helical Tooth M=36  $\Phi=1.4m$



链轮/ Chain Wheel  $\Phi=1.1m$



齿圈/ Girth Gear M=25  $\Phi=8.3m$



桥梁测量仪/ Bridge measuring instrument

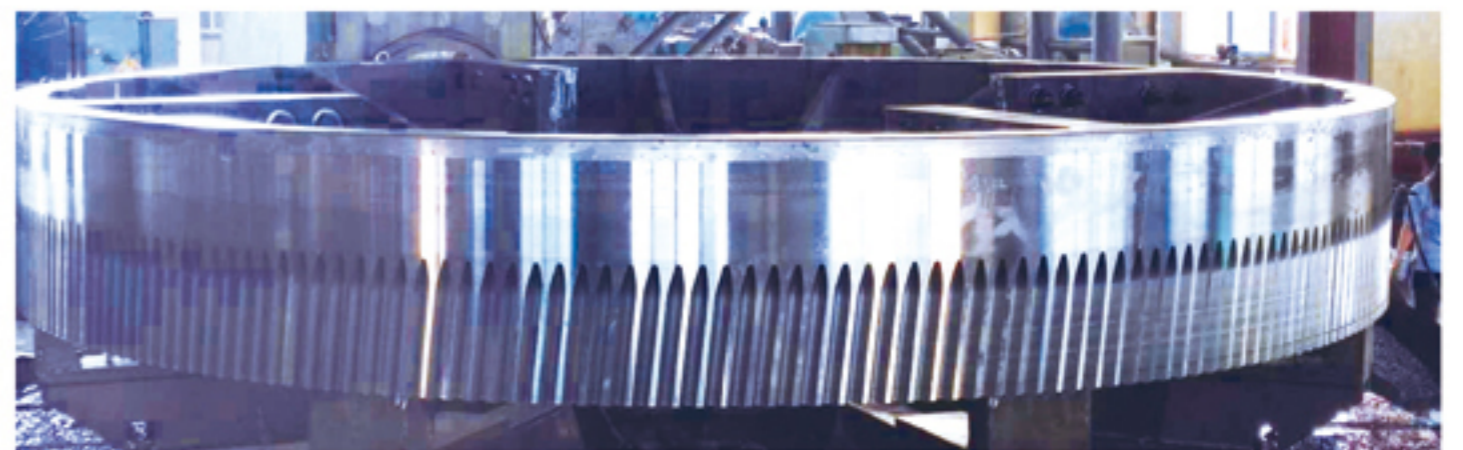

齿圈/ Girth Gear M=20  $\Phi=6.4m$

矿山备件

Mining Machine

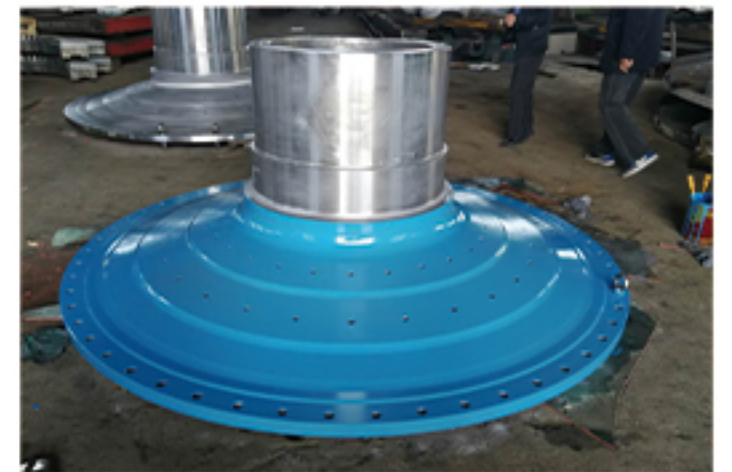
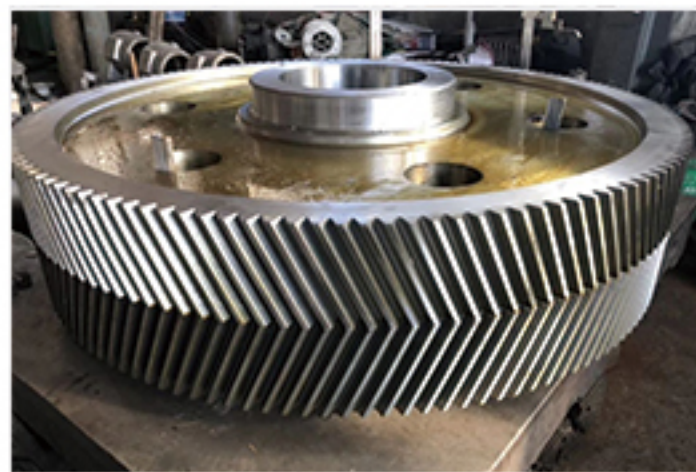
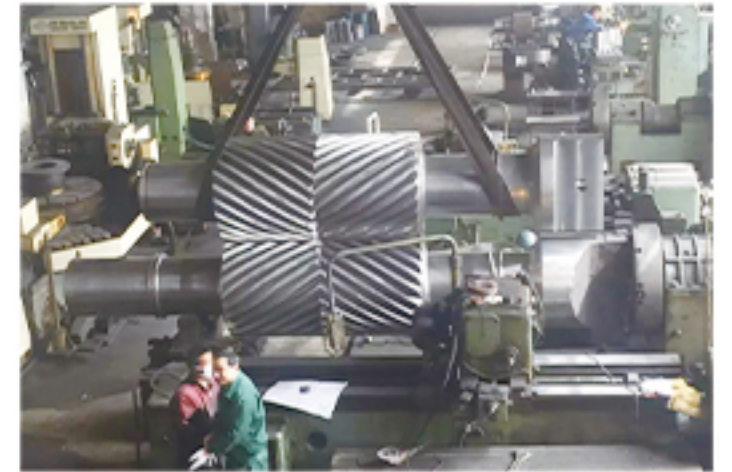
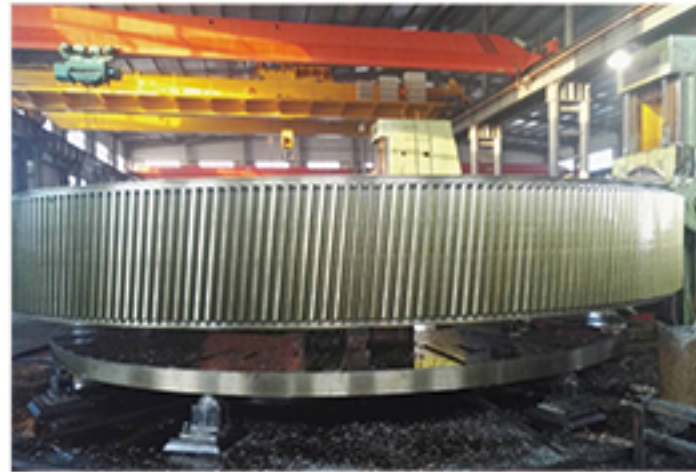
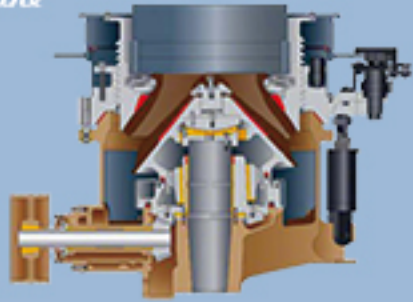

矿山备件  
Mining Machine

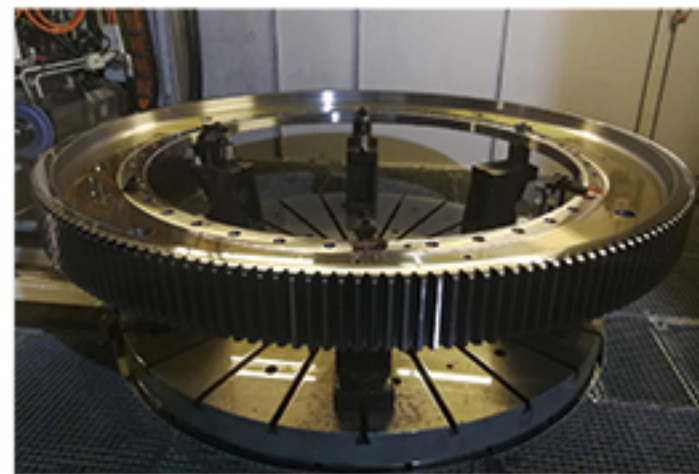
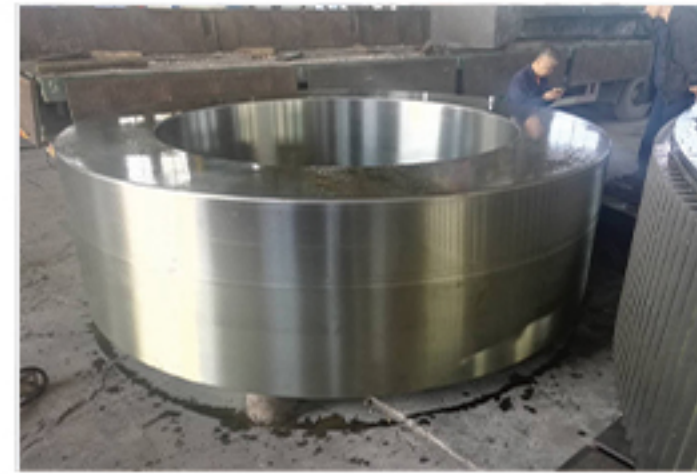



# 新福源

重型齿轮生产基地，轧臼壁，衬板

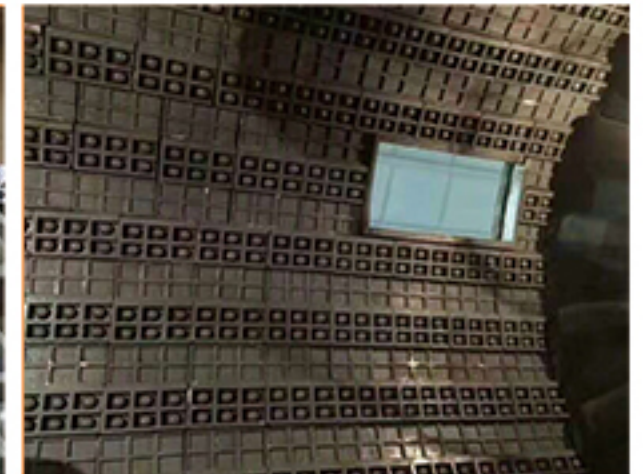
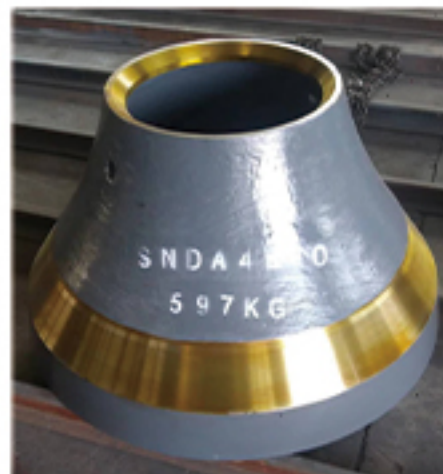
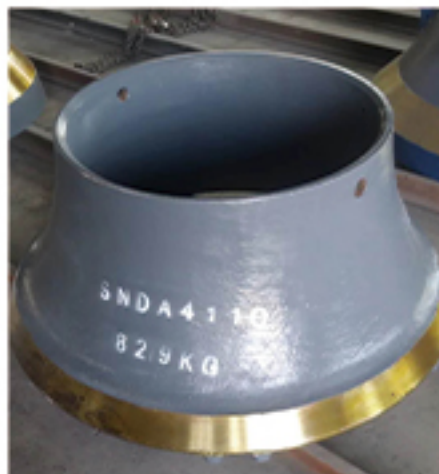

铝青铜和锡青铜备件

*Aluminium bronze,  
Tin bronze  
Spare parts*

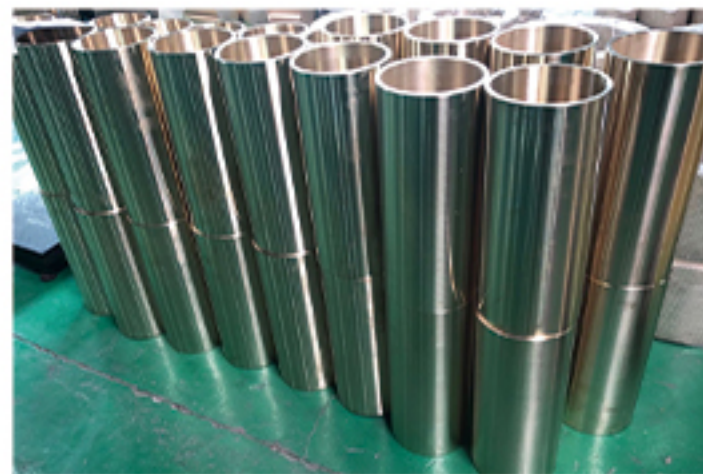
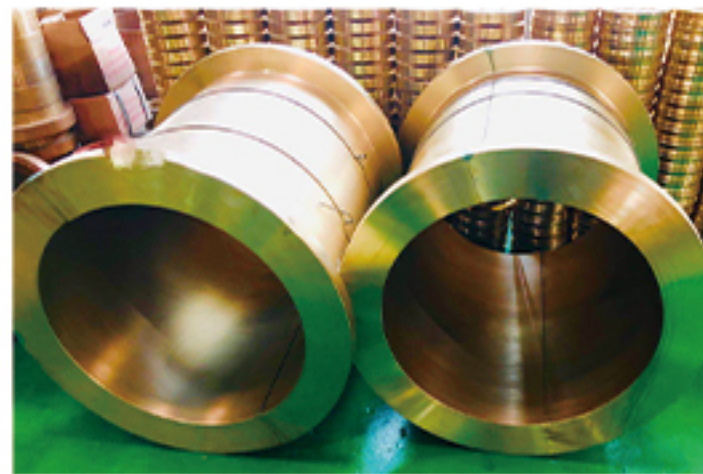
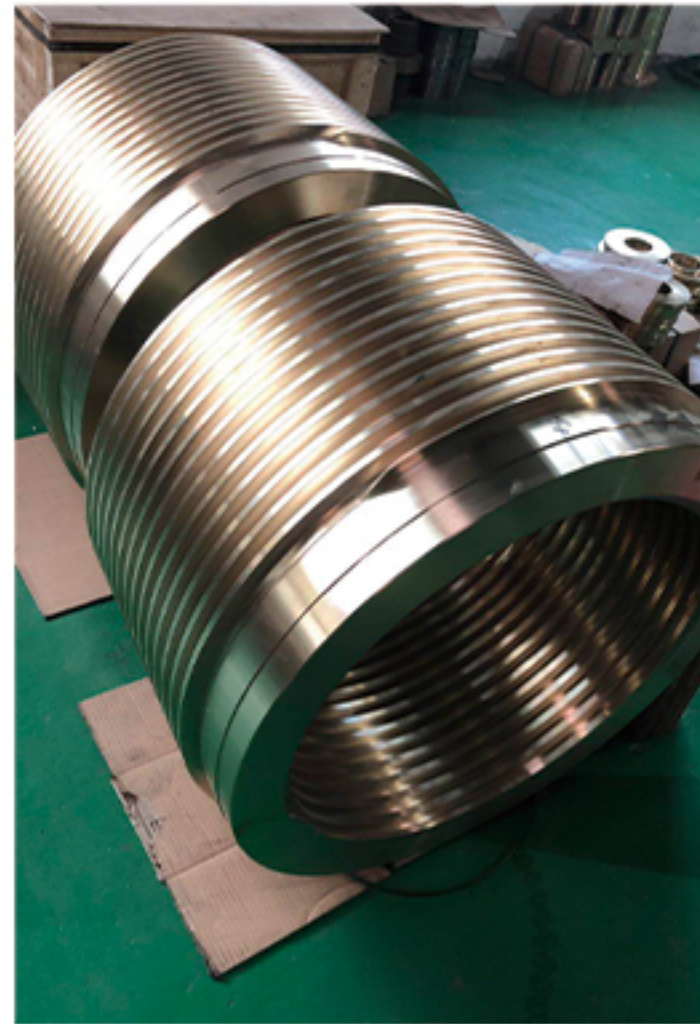

破碎机备件  
Parts Of Crusher

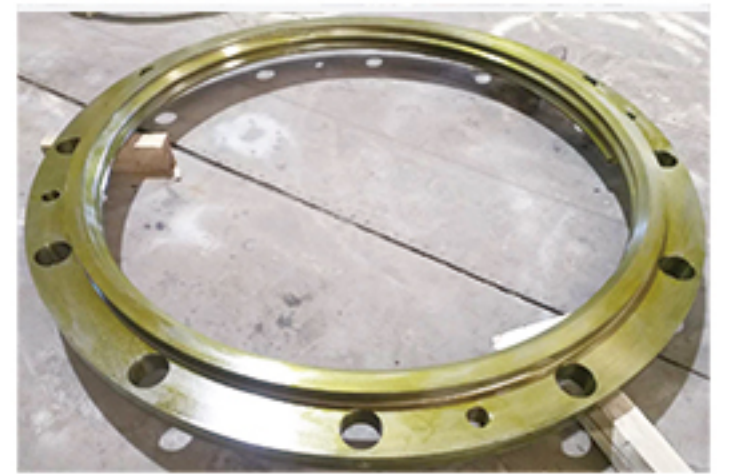
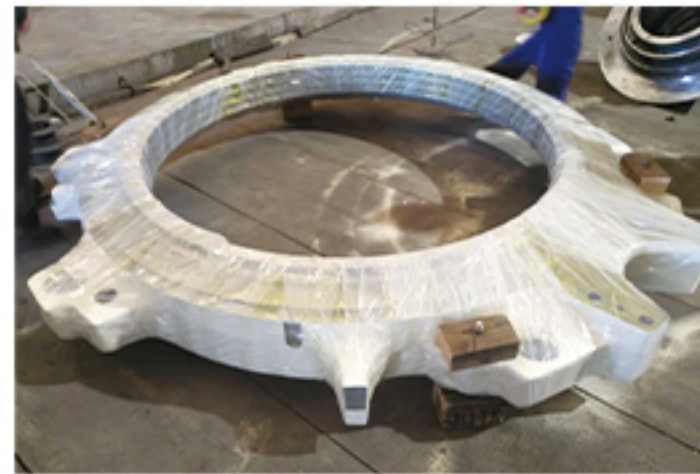
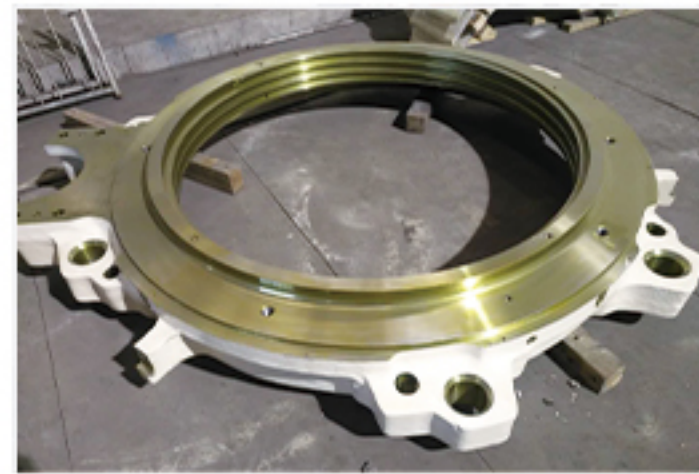
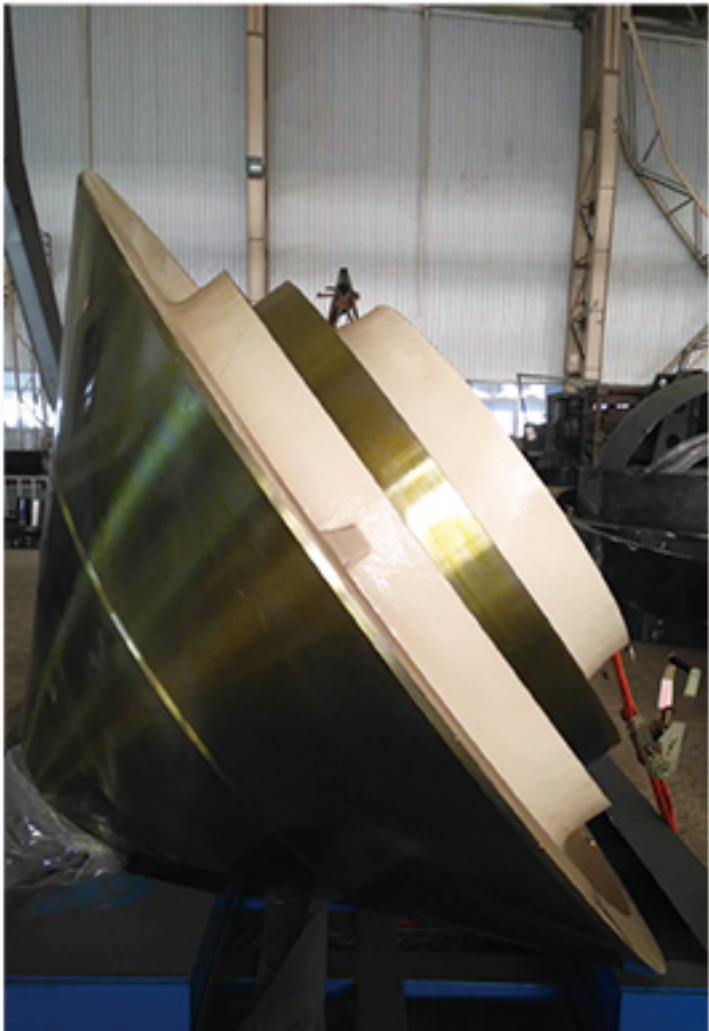
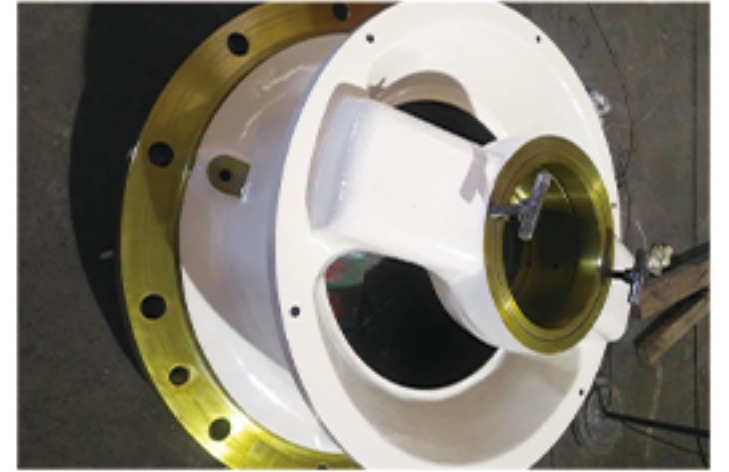
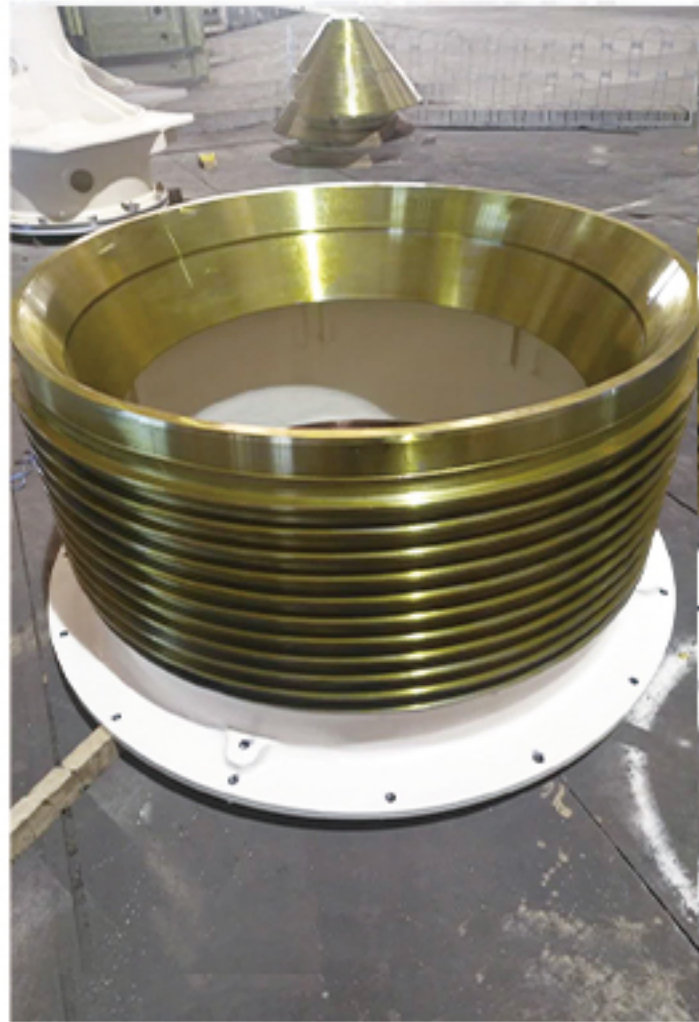
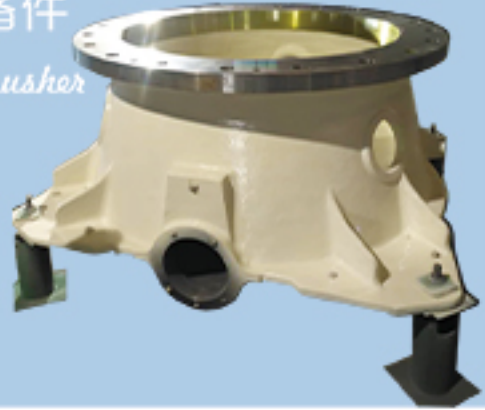



### 齿轮的应用

### *Gear Application*

专业加工大型直齿, 伞齿, 螺旋伞齿, 最大直径14m  
 Large gear, bevel gear, Spiral bevel gear, Max. diameter 14m



## 绳轮和卷筒

### *Rope Pulley and Rolling Drum*

专业生产绳轮，拥有专业加工设备若干台。另可加工卷筒。  
Rope pulley and rolling drum are produced by special equipment.



绳轮/ Rope Pulley



吊车卷筒/ Crane Hoisting Drum 100T





*Toothed Rack Application*  
齿条的应用

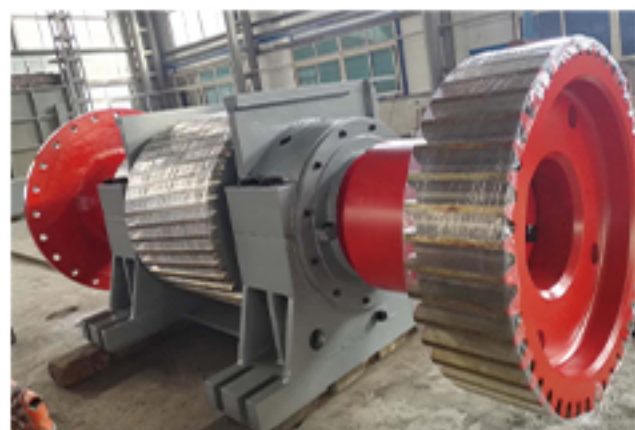

*Gear Coupling Application*  
齿接手的应用



### 回转支承的应用

### Slewing Ring Application

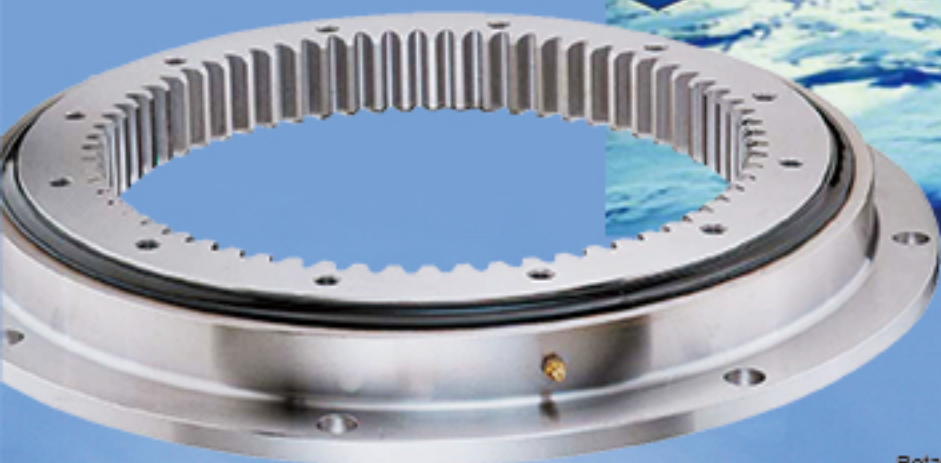

高精度回转支承 2008  
中国电子科技集团公司  
神州七号信息采集用转向轴承  
High precision slewing ring 2008  
China Electronics Technology Group Corporation  
Rotary slewing bearing of Information collection system for  
Shenzhou 7

NFB回转支承的显著特点如下：防水，防尘，防风沙；耐热，耐寒，耐腐蚀；精密，分体，高承载。特殊要求，特殊设计，特殊定制。

产品主要应用于军工和新能源开发、医疗设备、环保水下设备、高精度生产线、海上平台、近海设备、矿山机械、旋转输送装置、冶金机械、航天航空等特种领域。

NFB slewing ring excellent advantages: waterproof, dustproof, sand-proof; heat-resisting, cold-resisting, corrosion-resisting; High precision, Splitting, high loading; special requirement, special design, special customization.

NFB slewing ring can be used in many special field, such as war industry, new energy development field, Environmental protection underwater equipment, harbor machinery, mining machinery, rotating conveyer device, metallurgical machinery, aviation, filling machine, medical equipment and so on.



### 回转驱动的应用

### Slew Drive Application



高精度回转驱动  
机器人专用 2013  
新松机器人自动化股份有限公司  
High precision slewing ring For Robot 2013  
SIASUN Robot & Automation Co., Ltd.



- 整体设计偏向重型载荷,适用于高承载领域
- 常规型号现货库存
- 应用领域: 矿山设备, 军工设备, 冶金机械, 旋转输送装置, 医疗设备, 环保设备, 工程机械等
- 可根据使用情况特殊设计
- Heavy duty designing for high loading application.
- Normal types are in stock.
- Application: mining machinery, military industry, metallurgical machinery, rotating conveyer device, medical equipment, Environmental equipment, engineering machinery and so on.
- Customization accepted

